



TDFM-9000

MULTIBAND P25 AIRBORNE TRANSCEIVER



Installation Instructions

TiL Document No. 11RE442

Rev. B

Issue 4

OCTOBER 2013

Technisonic Industries Limited

240 Traders Boulevard, Mississauga, Ontario L4Z 1W7

Tel: (905) 890-2113 Fax: (905) 890-5338

www.til.ca

Copyright by Technisonic Industries Limited. All rights reserved.

TECHNISONIC INDUSTRIES LIMITED

| REVISION HISTORY [11RE442] | | | | |
|--|---------------------|---|---------------|--------------|
| REV | SECTION - PAGE - | DESCRIPTION | DATE | EDITED BY |
| A | 2-5 | Corrected Pin Numbers in Descriptions. | Mar 2013 | SM |
| B | iv | Corrected DO-160 Version and Categories. | July 2013 | SM |
| B – 1 | i | Updated TDFM-9000 Photo. | Aug 2013 | SM |
| B – 2 | 2-7 to 2-10 | Figures 2.2 – 2.5 Corrected. | Oct. 28, 2013 | AL |
| B – 3 | 2-1 | P/N in Section 2.4 Corrected. | Jan. 27, 2014 | AL |
| | All | Corrected Spelling & Grammar throughout document. | | |
| B – 4 | iv | Changed STC Approval Note. | May 12, 2014 | AL |
| | 1-2 | Added Special Order Band Codes. | | |
| | 1-2 and 2-7 | Specified “Section 2.17 Configuration Menu” Refers to TDFM-9000 Operating Instructions. | | |
| | 2-3 | Added Antenna & Connector Locations as well as Band Display Orientation. | | |
| | All | Changed Format for Section Headers. | | |

NOTES

ESD CAUTION



This unit contains static sensitive devices. Wear a grounded wrist strap and/or conductive gloves when handling printed circuit boards.

FCC COMPLIANCE INFORMATION

This device complies with Part 15 of the FCC Rules. Operation is subject to the following two conditions: (1) this device may not cause harmful interference and (2) this device must accept any interference received, including interference that may cause undesired operation.



WARNING: For compliance with FCC RF Exposure Requirements the mobile transmitter antenna installation shall comply with the following two conditions:

1. The transmitter antenna gain shall not exceed 3 dBi.
2. The transmitter antenna is required to be located outside of a vehicle and kept at a separation distance of 70 cm or more between the transmitter antenna of this device and persons during operation.

NOTE: This equipment has been tested and found to comply with the limits for a Class A digital device, pursuant to Part 15 of the FCC Rules. These limits are designed to provide reasonable protection against harmful interference when the equipment is operated in a commercial environment. This equipment generates, uses, and can radiate radio frequency energy and, if not installed and used in accordance with the instruction manual, may cause harmful interference to radio communications. Operation of this equipment in a residential area is likely to cause harmful interference, in which case the user will be required to correct the interference at his/her own expense.

WARNING AND DISCLAIMER

Changes or modifications not expressly approved by Technisonic Industries could void the user's authority to operate the equipment.

This manual is designed to provide information about the TDFM-9000. Every effort has been made to make this manual as complete and accurate as possible.

WARRANTY INFORMATION

The Model TDFM-9000 Transceiver is under warranty for one year from date of purchase. Failed units caused by defective parts or workmanship should be returned to:

Technisonic Industries Limited
240 Traders Boulevard
Mississauga, Ontario L4Z 1W7

Tel: (905) 890-2113
Fax: (905) 890-5338

TECHNISONIC INDUSTRIES LIMITED

SUMMARY OF DO-160G ENVIRONMENTAL TESTING

Summary of DO-160G Environmental Testing for Technisonic Model TDFM-9000 Transceiver:

| Conditions | Category |
|------------------------------------|-----------------|
| Temperature and Altitude | A2, B1, C4, D1 |
| Temperature Variation | B |
| Humidity | A |
| Operational Shock and Crash Safety | A |
| Vibration | S, U |
| Magnetic Effect | Z |
| Power Input | B |
| Voltage Spike | B |
| Audio Frequency Susceptibility | B |
| Induced Signal Susceptibility | AC |
| Radio Frequency Susceptibility | T |
| Radio Frequency Emission | M |
| Electrostatic Discharge | A |

INSTALLATION APPROVAL NOTE

Presently, no TSO standard exists for airborne FM transceivers. To make it easier for installation agencies to provide their customers with an approved installation supported by an effective Airworthiness Approval, Technisonic has secured Supplemental Type Certificate (STC) approval. The above referenced DO-160G test data is also on file and available from Technisonic to support approval requirements in airframes for which Technisonic does not possess an STC.

Approved aircraft types are listed in the attachments to the formal STC documents. These STCs are the exclusive property of Technisonic and require the written authority of Technisonic for their use. To assist Factory Authorized Technisonic Dealers in the certification process, we have placed copies of our Canadian and US STCs on our website along with a letter of authorization for their use. These documents may be downloaded and used as support for the technical submission to FAA or Transport Canada. Only authorized factory dealers/installers are permitted to download and make use of these documents on behalf of their customers (end users) in support of regulatory agency approval. Please refer to the Technisonic website www.til.ca for the latest issue of available STCs and letter of authorization for use.

Trademark Notices

TDFM-9000 Transceivers contain two-way radio protocols licensed from Motorola, Inc.

© 1997, 1998 Motorola, Inc.

Motorola KVL 3000+® is a registered trademark of Motorola.

TABLE OF CONTENTS

| SECTION | TITLE | PAGE |
|--|---|------|
| SECTION 1 GENERAL DESCRIPTION | | |
| 1.1 | INTRODUCTION | 1-1 |
| 1.2 | DESCRIPTION | 1-1 |
| 1.3 | MODEL VARIATION | 1-1 |
| 1.4 | TECHNICAL CHARACTERISTICS | 1-3 |
| SECTION 2 INSTALLATION INSTRUCTIONS | | |
| 2.1 | GENERAL | 2-1 |
| 2.2 | EQUIPMENT PACKING LOG | 2-1 |
| 2.3 | INSTALLATION | 2-1 |
| 2.4 | INSTALLATION KIT – CONTENTS | 2-1 |
| 2.5 | ANTENNA INSTALLATION | 2-1 |
| 2.6 | INSTALLATION – PIN LOCATIONS AND CONNECTIONS | 2-4 |
| 2.7 | INSTALLATION – WIRING INSTRUCTIONS | 2-6 |
| 2.8 | MAIN GROUND – J1 PINS 1 AND 14 | 2-6 |
| 2.9 | MAIN POWER + 28VDC – J1 PINS 2 AND 15 | 2-6 |
| 2.10 | MIC 1, 2, 3, 5, 6, AND 4 – J1 PINS 3, 6, 9, 19, 22, AND J6 PIN 6..... | 2-6 |
| 2.11 | MIC COMBINED 1 AND 2 – J6 PINS 7 AND 13 | 2-6 |
| 2.12 | AUDIO 1, 2, 3, 5, 6, AND 4 – J1 PINS 4, 7, 10, 20, 23, AND J6 PIN 5 | 2-6 |
| 2.13 | AUDIO COMBINED 1 AND 2 – J6 PINS 2 AND 10 | 2-6 |
| 2.14 | PTT 1, 2, 3, 5, 6, AND 4 – J1 PINS 5, 8, 11, 21, 24, AND J6 PIN 3 | 2-7 |
| 2.15 | PTT COMBINED 1 AND 2 – J6 PINS 4 AND 12..... | 2-7 |
| 2.16 | TX DATA AND RX DATA – J1 PINS 12 AND 13..... | 2-7 |
| 2.17 | UP AND DOWN – J1 PINS 16 AND 17 | 2-7 |
| 2.18 | CHANNEL/BAND – J1 PIN 18 | 2-7 |
| 2.19 | PANEL BACKLIGHTING – J1 PIN 25..... | 2-7 |
| 2.20 | SPEAKER LO AND HI – J6 PINS 8 AND 9..... | 2-7 |
| 2.21 | ANTENNA SELECTION AND INSTALLATION CONSIDERATIONS..... | 2-13 |
| 2.22 | POST INSTALLATION EMI TEST | 2-13 |
| | APPENDIX A Support Notes | 2-24 |
| | WARRANTY | 2-25 |

LIST OF FIGURES

| FIGURE | TITLE | PAGE |
|--------|---|------|
| 2.1 | Outline Drawing | 2-2 |
| 2.2 | TDFM-9000 Antenna & Connector Locations | 2-3 |
| 2.3 | TDFM-9000 Band Display Orientation | 2-3 |
| 2.4 | Wiring Connections for Individual Band Control with Separate Ground Returns | 2-8 |
| 2.5 | Wiring Connections for Individual Band Control with a Single Ground Return | 2-9 |
| 2.6 | Wiring Connections for Combined Band Control with Separate Ground Returns | 2-10 |
| 2.7 | Wiring Connections for Combined Band Control with a Single Ground Return | 2-11 |
| 2.8 | Wiring Connection Notes for the TDFM-9000 Transceiver | 2-12 |

LIST OF TABLES

| TABLE | TITLE | PAGE |
|-------|--|------|
| 2.1 | J1 25 Pin D Connections | 2-3 |
| 2.2 | J6 15 Pin High Density D Connections | 2-4 |
| 2.3 | J5 15 Pin High Density D Connections | 2-4 |

SECTION 1: GENERAL DESCRIPTION

1.1 INTRODUCTION

This publication provides operating information on the TDFM-9000 airborne transceiver. The exact configuration depends on which and how many RF modules are installed.

1.2 DESCRIPTION

The TDFM-9000 transceiver is an airborne multi-band radio capable of operation in conventional analog and P25 digital FM systems, SmartNet/SmartZone trunking systems, and P25 9600 trunking systems. RF modules are available in single or dual bands that support VHF, UHF-LO, UHF-HI, and 700-800 MHz bands. Up to 6 single or dual band modules can be supported.

These optional additional features include P25 9600 trunking Phase 1 and 2 that may be combined with AES and/or DES-OFB encryption with OTAR in any of the available modules.

The TDFM-9000 is not normally frequency agile. In order to have the ability to change the frequencies at the front panel, the FPP (front panel programming) option must be ordered for each band. FPP is only available on the VHF and UHF modules.

1.3 MODEL VARIATION

There are several variations of the Model TDFM-9000 Transceiver. Each variation offers different features and performance based on the type of RF modules and options installed.

RF Modules are mounted in trays of two (with up to 3 trays supported).
The following is a breakdown of the TDFM-9000 model variations:

P/N 101263-D-90-TBB-TBB-TBB-P9XXXX

(PRODUCT TYPE)-(D)-(9X)-(Tray 1)-(Tray2)-(Tray3)-(Project)

PRODUCT TYPE: 101263 = TDFM-9000 series, 3 trays, 2 – 6 modules

D= Display type:

- 1) Color TFT
- 2) Standard Green/NV

9X = TDFM-9000 series variant:

90 = TDFM-9000

TECHNISONIC INDUSTRIES LIMITED

Tray Breakdown: (TBB):

T= Module type: A= T30xx RF modules (Single or Dual)

B is Band code for each module in the tray.

Band Codes

| | |
|-----|-------------------|
| 1 | VHF (136-174) |
| 2 | UHF LO (380-470) |
| 3 | UHF HI (450-520) |
| 4 | 700/800 (764-870) |
| A | V/700/800 |
| B | V/UHF LO |
| C | V/UHF HI |
| D | UL/UH |
| E | UL/700/800 |
| F | UH/700/800 |
| * G | 700/800/V |
| * H | 700/800/UL |
| * I | 700/800/UH |
| * J | UHF LO/V |
| * K | UHF HI/V |
| * L | UH/UL |

Band numbers indicate single band modules and letters indicate dual band modules.

* Band codes are special order and are not standard configuration.

Project Number: P9XXXX represents a 5-digit project number that identifies specific options that are contained in each module and describes the full TDFM-9000 configuration.

All model variations are capable of supporting both 28 Volt and 5 Volt AC or DC back lighting. The units are shipped set to operate on 28 Volt back lighting. Equipment can be set to operate on 5V back lighting by using the software based configuration menu. See Section 2.17 Configuration Menu in the TDFM-9000 Operating Instructions available at www.til.ca. Damage will not occur if the incorrect voltage is applied.

TECHNISONIC INDUSTRIES LIMITED

1.4 TECHNICAL CHARACTERISTICS

| <u>Specification</u> | <u>Characteristic</u> |
|--|---|
| Model Designation: | TDFM-9000 |
| Physical Dimensions: | Approx. (L) 8.0" x (W) 5.75" x (H) 4.5" |
| Weight: | ~7.0 Lbs (3.2 Kg) |
| Operating Temperature Range: | -30° C to +60° C |
| Power Requirement: | |
| Voltage: | 28.0 VDC ± 15% |
| Current: | 500 mA minimum / 7.5A maximum |
| Audio Output Power (including sidetone): | 65 mW into 600 Ω |
| Microphone Inputs: | Carbon or Equivalent |
| Panel Back Lighting: | |
| Voltage: | 28 or 5 Volts AC or DC (selectable) |
| Current: | 10 uA |

RF Modules

| <u>Specification</u> | <u>Characteristic</u> |
|---------------------------|--|
| RF Output Power: | 1 or 6 Watts (VHF) 1 or 5 Watts (UHF) 1 or 3 Watts (700/800) |
| Frequency Range | |
| VHF Band: | 136 to 174 MHz |
| UHF LO Band: | 380 to 470 MHz |
| UHF HI Band: | 450 to 520 MHz |
| 700 / 800 Bands: | 764 to 870 MHz |
| No. of channels per band: | 2000 pre-programmable channels |

Transmitter section

| | VHF | UHF | 800 |
|------------------------------------|-------------|------------|------------|
| FM Hum and noise in dB (wideband): | -48 | -45 | -45 |
| Audio Distortion: | 1% | 1.0% | 1.0% |
| Frequency Stability in ppm: | ± 1.0 | ± 1.0 | ± 1.5 |
| Modulation Limiting: | Wide band | ± 5 kHz | |
| | Narrow band | ± 2.5 kHz | |

Receiver section

| | VHF | UHF | 800 |
|-------------------------------|------------|------------|------------|
| <i>Sensitivity</i> in uV: | | | |
| * Digital 1% BER (12.5 kHz) | 0.29 | 0.32 | 0.40 |
| * Digital 5% BER (12.5 kHz) | 0.21 | 0.28 | 0.30 |
| ** Analog with 12 dB SINAD | 0.25 | 0.25 | 0.25 |
| <i>Selectivity</i> in dB: | | | |
| 25 kHz Channel | -80 | -78 | -72 |
| 12.5 kHz Channel | -70 | -68 | -67 |
| Intermodulation * ** | -80 | -80 | -80 |

* Measured in digital mode per TIA / EIA IS 102.CAAA under nominal conditions.

** Measured in analog mode per TIA / EIA 603 under nominal conditions.

SECTION 2: INSTALLATION INSTRUCTIONS

2.1 GENERAL

This section contains information and instructions for the correct installation of the TDFM-9000 Transceiver.

2.2 EQUIPMENT PACKING LOG

Unpack the equipment and check for any damage that may have occurred during transit. Save the original shipping container for returns due to damage or warranty claims. Check that each item on the packing slip has been shipped in the container.

2.3 INSTALLATION

The TDFM-9000 Transceiver is designed to be Dzus mounted and should be installed in conjunction with an IN-9000 installation kit. See Figure 2.1 for an outline drawing of the unit with dimensions to facilitate the installation.

2.4 INSTALLATION KIT - CONTENTS

The IN-9000 installation kit (P/N 129292) consists of:

1. One 25 Pin Cannon D mating connector (female) complete with crimp pins and hood.
2. One 15 Pin HD Cannon D mating connector (female) complete with crimp pins and hood.
3. One 15 Pin HD Cannon D mating connector (male) complete with crimp pins and hood.
4. 6 BNC connectors.

2.5 ANTENNA INSTALLATION

The type and number of antennas depends on the model of transceiver being installed. The following is a list of recommended antennas for the various RF modules:

| | | | |
|-------------|----------------|--------|-----------------------|
| VHF | 136 to 174 MHz | Comant | Part # CI-292-3 or -4 |
| UHFLO | 403 to 470 MHz | Comant | Part # CI-275 |
| UHFHI | 450 to 520 MHz | Comant | Part # CI-285 |
| 800 | 800 to 870 MHz | Comant | Part # CI-306 |
| 800/700 | 764 to 870 MHz | Comant | Part # CI-285 |
| VHF/UHF/800 | Multiband | Rami | Part # AV-925 |

The antenna should be mounted on the bottom of the aircraft whenever possible. Consult with instructions provided with the antenna. Connect the RF cables to the back of the transceiver using the MALE BNC connectors provided in the installation kit. It is possible to use equivalent 50 ohm aviation antennas that cover the appropriate bandwidths.

TECHNISONIC INDUSTRIES LIMITED

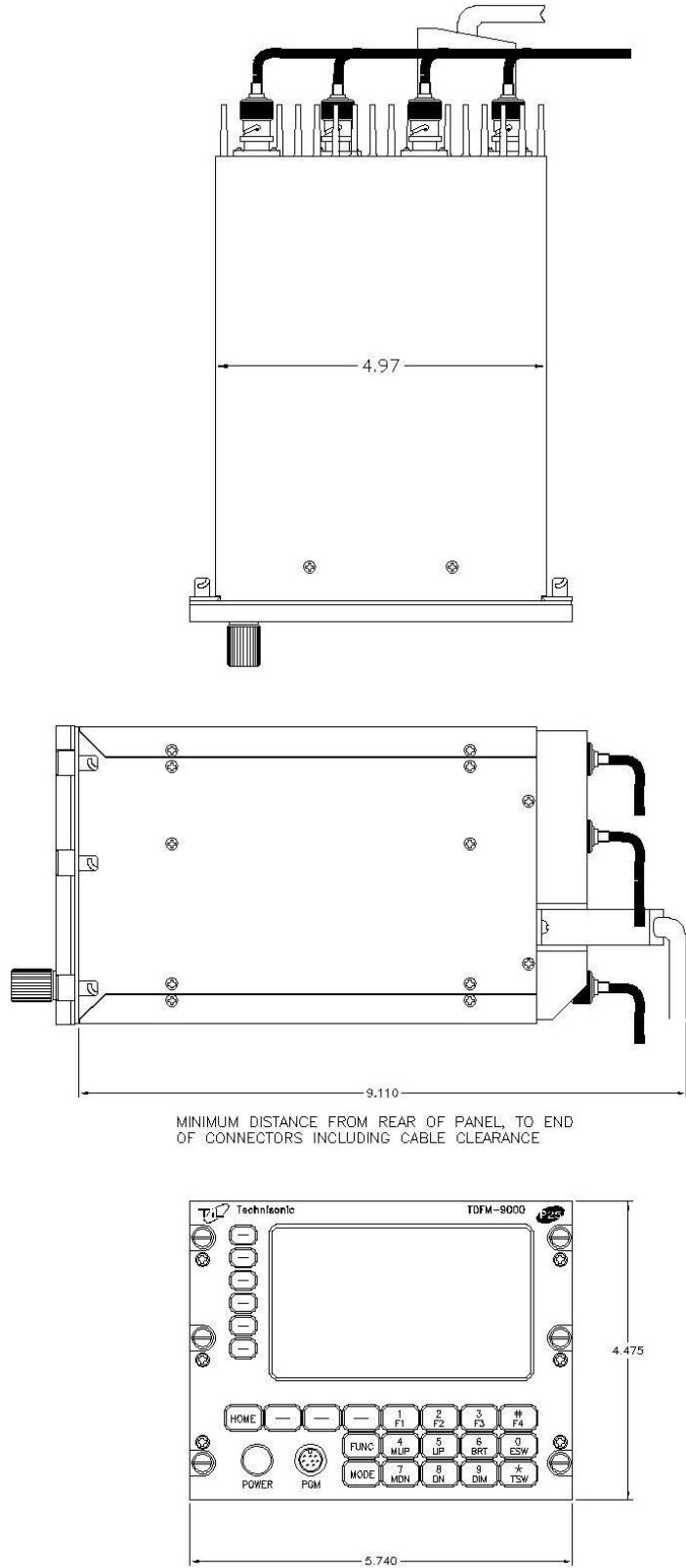

FIGURE 2.1 Outline Drawing for Model TDFM-9000

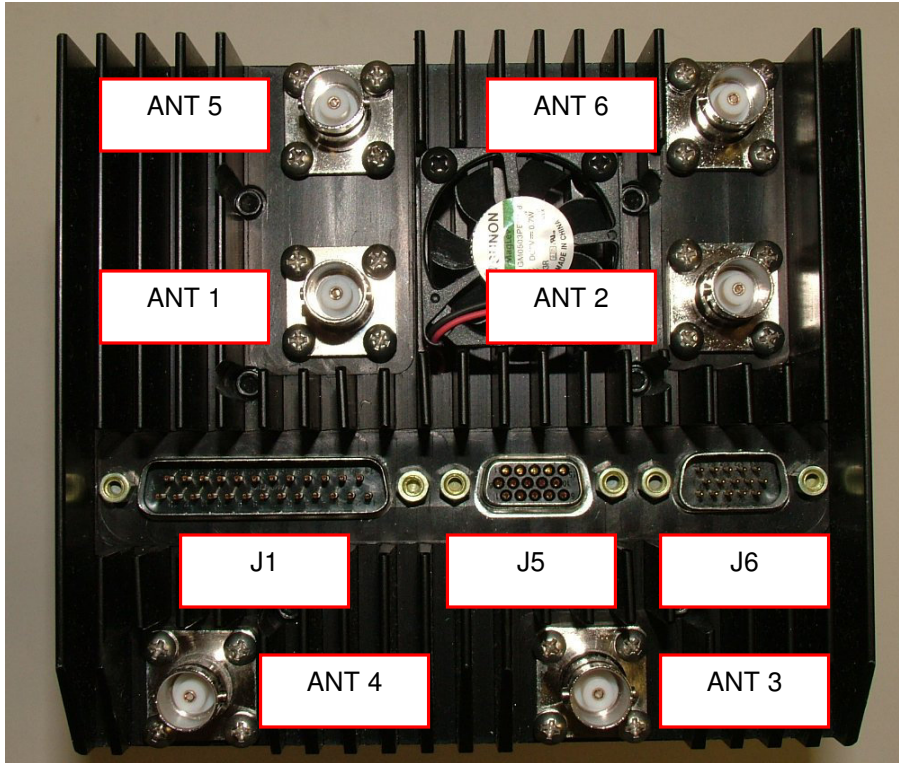

Figure 2.2 TDFM-9000 Antenna & Connector Locations



Figure 2.3 TDFM-9000 Band Display Orientation

Band display corresponds to the antenna connector numbering and radio ports. Band 1 (top of the display) is connected the ANT 1 and uses the Band 1 connections on the interface connectors.

2.6 INSTALLATION - PIN LOCATIONS AND CONNECTIONS

| J1 (25 Pin D Connections) - Use FEMALE Connector | |
|--|--------------------|
| Pin # | Description |
| 1 | Ground |
| 2 | Main Power +28 VDC |
| 3 | Mic 1 |
| 4 | Audio 1 |
| 5 | PTT 1 |
| 6 | Mic 2 |
| 7 | Audio 2 |
| 8 | PTT 2 |
| 9 | Mic 3 |
| 10 | Audio 3 |
| 11 | PTT 3 |
| 12 | TX Data |
| 13 | RX Data |
| 14 | Ground |
| 15 | Main Power +28 VDC |
| 16 | Up |
| 17 | Down |
| 18 | Channel / Band |
| 19 | Mic 5 |
| 20 | Audio 5 |
| 21 | PTT 5 |
| 22 | Mic 6 |
| 23 | Audio 6 |
| 24 | PTT 6 |
| 25 | Panel Backlighting |

TABLE 2.1 J1 (25 Pin D) Connections

TECHNISONIC INDUSTRIES LIMITED

| J6 (15 Pin High Density D Connections) – Use FEMALE Connector | |
|---|-------------------------|
| Pin # | Description |
| 1 | Ground |
| 2 | Audio Combined 1 |
| 3 | PTT4 |
| 4 | PTT Combined 1 |
| 5 | Audio 4 |
| 6 | Mic 4 |
| 7 | Mic Combined 1 |
| 8 | Speaker Lo |
| 9 | Speaker Hi |
| 10 | Audio Combined 2 |
| 11 | Misc In |
| 12 | PTT Combined 2 |
| 13 | Mic Combined 2 |
| 14 | Misc In/Out |
| 15 | Audio Combined Ground 2 |

TABLE 2.2 J6 (15 Pin HDD) Connections

| J5 (15 Pin High Density D Connections) – Use MALE Connector | |
|---|-------------------------|
| Pin # | Description |
| 1 | Audio 2 |
| 2 | Audio 5 |
| 3 | Audio 6 |
| 4 | Audio 3 |
| 5 | Audio 4 |
| 6 | Audio Ground 2 |
| 7 | Audio Ground 5 |
| 8 | Audio Ground 6 |
| 9 | Audio Ground 3 |
| 10 | Audio Ground 4 |
| 11 | Audio 1 |
| 12 | Audio Ground 1 |
| 13 | Ground |
| 14 | Audio Combined Ground 1 |
| 15 | Audio Combined 1 |

TABLE 2.3 J5 (15 Pin HDD) Connections

2.7 INSTALLATION - WIRING INSTRUCTIONS

Figure 2-2(a, b, and c) show all required connections and recommended wire sizes for the TDFM-9000 transceiver. The TDFM-9000 allows for either a single audio output ground or separate grounds for each audio output. If a single point ground is required for a pre-existing installation, the dongle supplied in the installation kit must be plugged into J5. If this is a new installation, it is recommended to use the isolated ground returns to the audio panel for reduced cross talk between bands and airframe noise. The audio panel must have isolated grounds for each audio input (such as Technisonic's A710, A711, A711L, and TDAP-711) to take advantage of this feature. There are receive audio, mic audio, and Push To Talk (PTT) lines for each band as well as two sets of lines combining all six bands. The TDFM-9000 can be wired such that band selection can be made on the audio panel. Up to 6 positions need to be available on the audio panel; otherwise, the TDFM-9000 can be wired into one or two positions of the audio panel where band selection and audio monitoring is done on the TDFM-9000 front panel. An installation can be wired in a combination of both methods since all inputs and outputs are always active.

2.8 MAIN GROUND – J1 PINS 1 AND 14

Both pins should be connected to power ground. These pins are internally connected to the chassis.

2.9 MAIN POWER + 28VDC – J1 PINS 2 AND 15

Both pins should be connected to +28 volts DC \pm 15%.

2.10 MIC 1, 2, 3, 5, 6, AND 4 – J1 PINS 3, 6, 9, 19, 22, AND J6 PIN 6

The microphone input signals shall be connected using shielded wire with the shield connected to ground (pin 1 or 14). For best results, it is recommended to leave the other end of the shield floating to prevent ground currents unless you are connecting to an audio panel with floating hi and lo inputs (like the Technisonic A710, A711, A711L, or TDAP-711) in which case the shield must be connected to the lo input. These are individual inputs for each band.

2.11 MIC COMBINED 1 AND 2 – J6 PINS 7 AND 13

The combined mic inputs should be wired and shielded like the individual mic inputs above. These mic inputs can be used for any band. Band selection is made at the TDFM-9000 front panel.

2.12 AUDIO 1, 2, 3, 5, 6, AND 4 – J1 PINS 4, 7, 10, 20, 23, AND J6 PIN 5

These are individual audio outputs from each band. All outputs are 600 ohms impedance. The output power is 65 mW maximum. Unused outputs do not have to be terminated and should be left unconnected. These outputs are also found on J5 along with their respective grounds such that a separate wire bundle can be run with only audio outputs, further reducing the possibility of cross talk.

2.13 AUDIO COMBINED 1 AND 2 – J6 PINS 2 AND 10

These are combined audio outputs from all bands as selected from the front panel. The specifications are the same as the individual outputs above.

TECHNISONIC INDUSTRIES LIMITED

2.14 PTT 1, 2, 3, 5, 6, AND 4 – J1 PINS 5, 8, 11, 21, 24, AND J6 PIN 3

There are individual PTT lines for each band. These lines should be floating when in receive and grounded for transmit. The input has a pull up resistor to 5 volts. Connecting an audio panel that wishes to see more may result in no receive audio. Connect a 1N4006 diode in series with the cathode towards the audio panel in this case.

2.15 PTT COMBINED 1 AND 2 – J6 PINS 4 AND 12

These are combined PTT inputs to all bands as selected from the front panel. The specifications are the same as the individual inputs above.

2.16 TX DATA AND RX DATA – J1 PINS 12 AND 13

These pins provide RS-232 serial communications for use with the RC-9000 remote control head if installed. Consult the RC-9000 installation manual for details.

2.17 UP AND DOWN – J1 PINS 16 AND 17

These pins can be used to scroll up and down through the bands or channels for the band currently selected depending on the band input below. The inputs normally floating are grounded to activate. Two push buttons or a center off, SPDT, spring-loaded toggle switch are typically used on these inputs.

2.18 CHANNEL/BAND – J1 PIN 18

The Channel / Band input determines the function of the up down inputs above. If left unconnected, the inputs are for channel selection. If grounded, the input is for band selection.

2.19 PANEL BACKLIGHTING – J1 PIN 25

Connect to aircraft panel dimming bus. The transceiver is capable of supporting 28 VAC/DC or 5 VAC/DC backlighting circuits. Select 28 volts or 5 volts via the configuration menu (see Section 2.17 of the TDFM-9000 Operating Instructions). No damage will occur if the wrong setting is made.

2.20 SPEAKER LO AND HI – J6 PINS 8 AND 9

Not normally connected in the aircraft. This output is 4 / 8 ohms at 1.1 watts max and has the audio associated with Audio Combined 1. This output does not have to be terminated when not used and should be left unconnected.

TECHNISONIC INDUSTRIES LIMITED

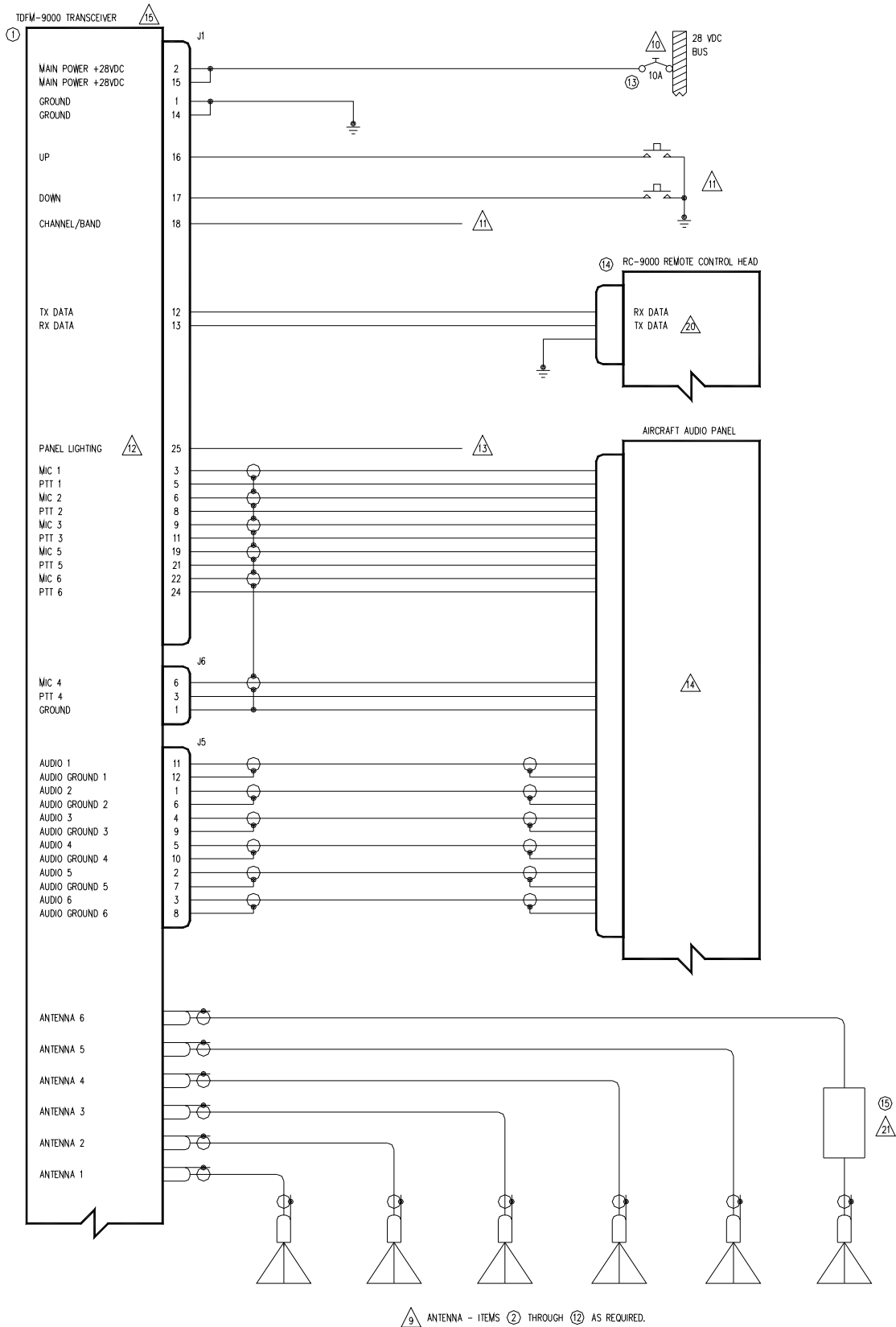

FIGURE 2.4 Wiring Connections for Individual Band Control with Separate Ground Returns

TECHNISONIC INDUSTRIES LIMITED

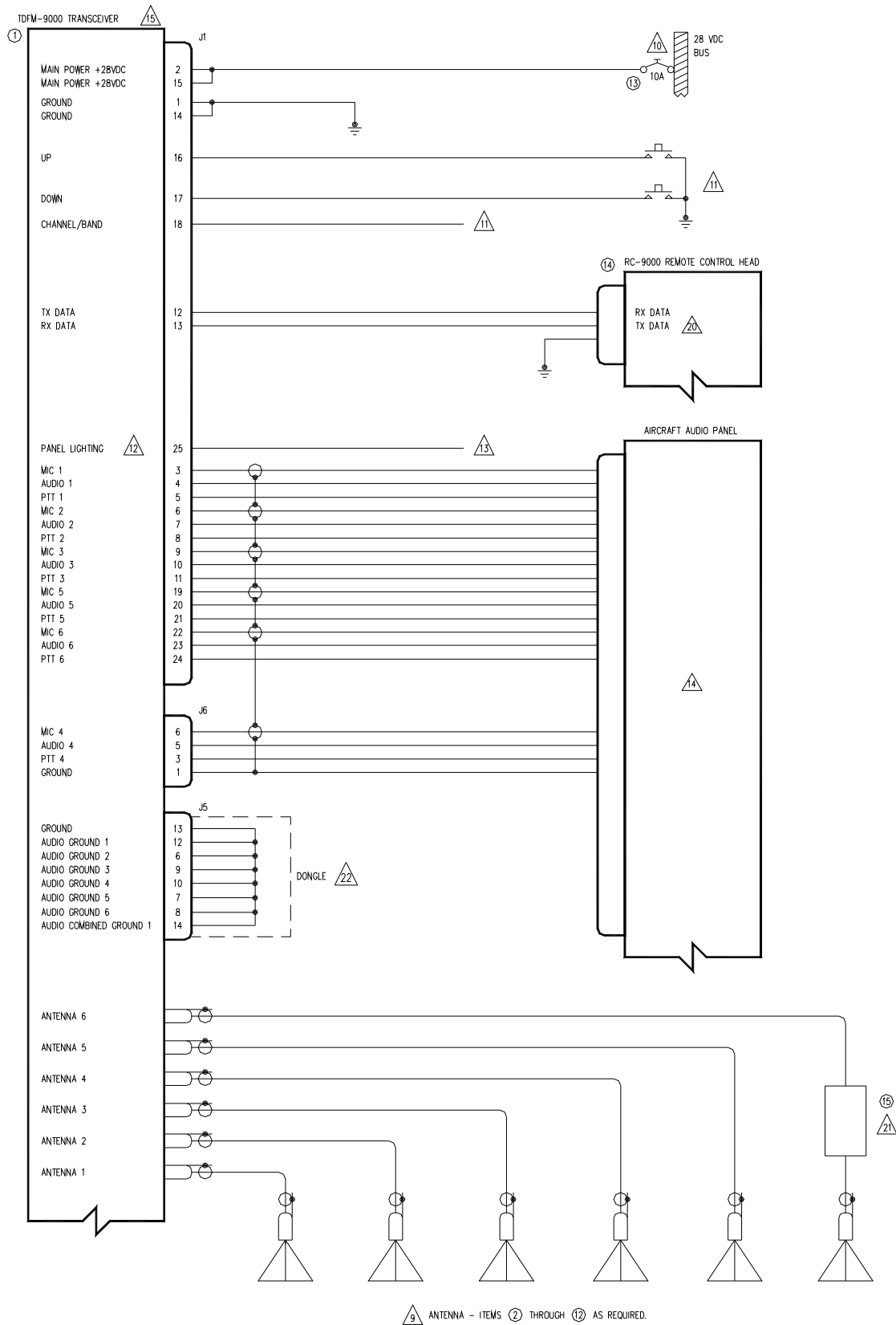

FIGURE 2.5 Wiring Connections for Individual Band Control with a Single Ground Return

TECHNISONIC INDUSTRIES LIMITED

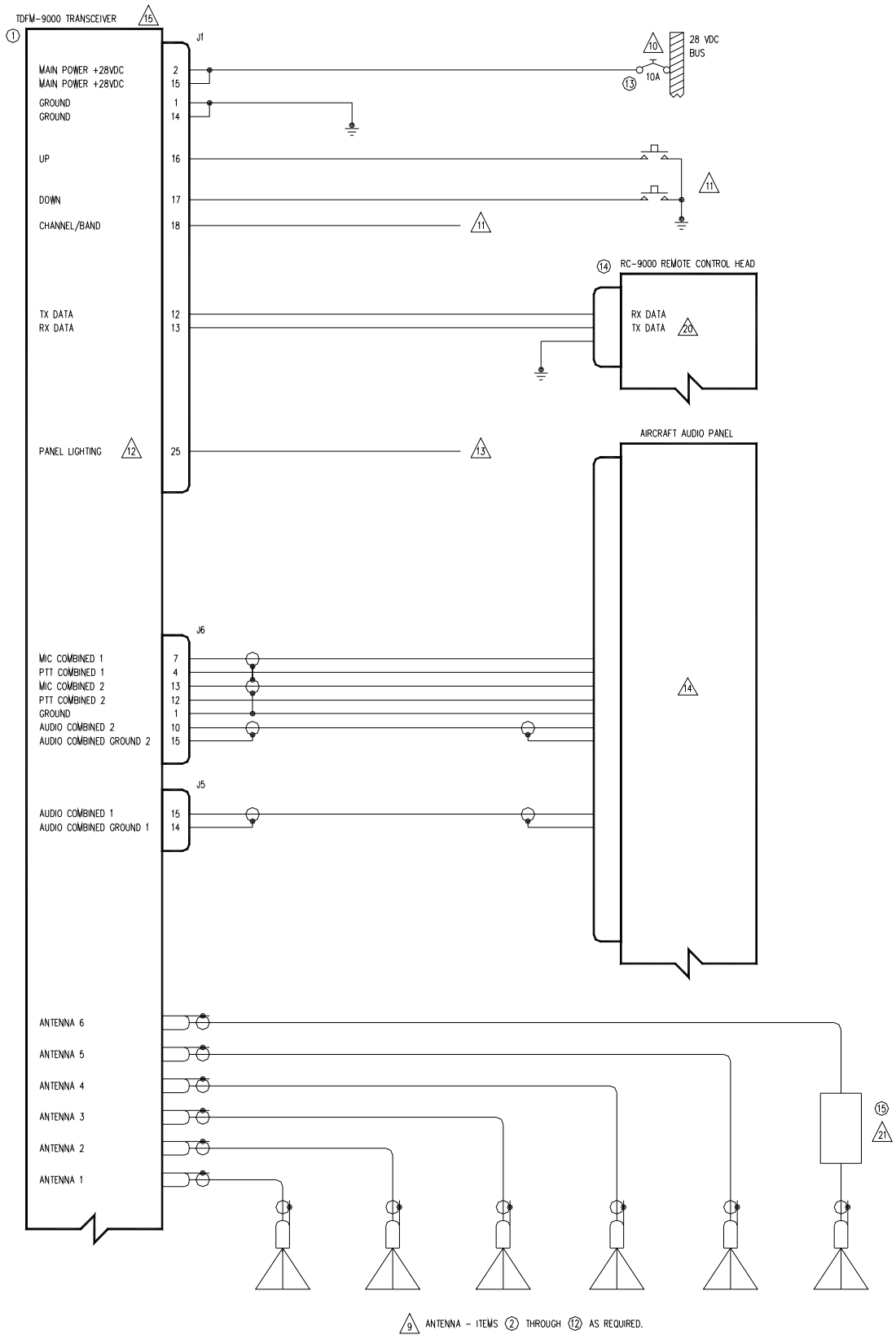

FIGURE 2.6 Wiring Connections for Combined Band Control with Separate Ground Returns

TECHNISONIC INDUSTRIES LIMITED

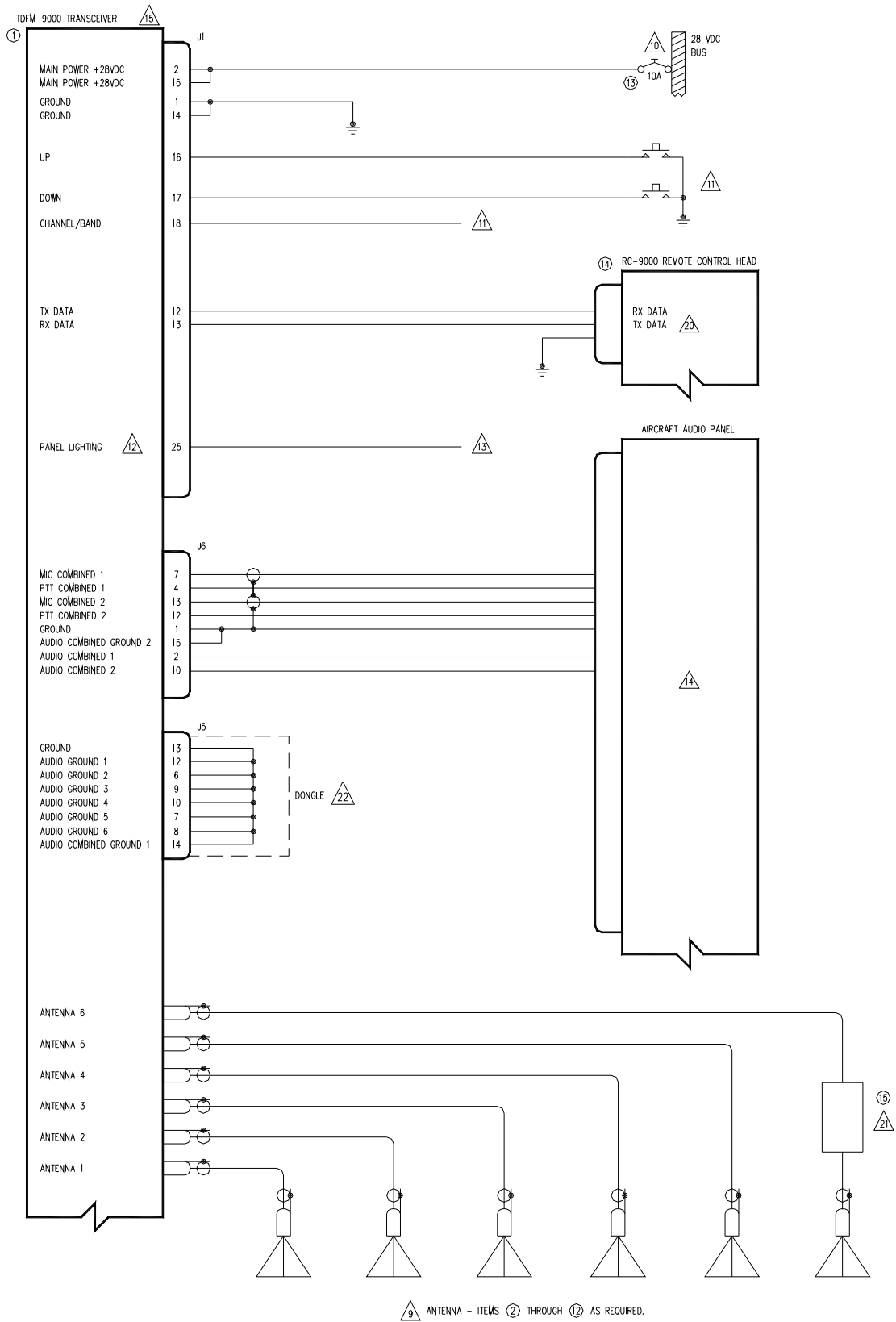

FIGURE 2.7 Wiring Connections for Combined Band Control with a Single Ground Return

TECHNISONIC INDUSTRIES LIMITED

| QTY | ITEM | PART NUMBER | DESCRIPTION | MANUFACTURER | MATERIAL |
|-----|------|-------------|---|--------------------------------|----------|
| 1 | 1 | TDFM-9000 | MULTIBAND FM COMMUNICATIONS TRANSCEIVER. | TECHNISONIC INDUSTRIES LIMITED | |
| A/R | 2 | CI-292-3 | VHF ANTENNA, 138 TO 174 MHz | COMANT INDUSTRIES | |
| A/R | 3 | CI-292-4 | VHF ANTENNA, 136 TO 174 MHz | COMANT INDUSTRIES | |
| A/R | 4 | CI-275 | UHFLO ANTENNA, 403 TO 470 MHz | COMANT INDUSTRIES | |
| A/R | 5 | CI-275 | UHFHI ANTENNA, 450 TO 512 MHz | COMANT INDUSTRIES | |
| A/R | 6 | CI-285 | UHFHI (II) ANTENNA, 450 TO 520 MHz | COMANT INDUSTRIES | |
| A/R | 7 | CI-306 | 800 ANTENNA, 806 TO 870 MHz | COMANT INDUSTRIES | |
| A/R | 8 | CI-285 | 800/700 (II) ANTENNA, 700 TO 870 MHz | COMANT INDUSTRIES | |
| A/R | 9 | CI-295-200 | VHF/UHF ANTENNA, 136 TO 174 / 380 TO 520 MHz | COMANT INDUSTRIES | |
| A/R | 10 | CI-295-250 | VHF/700/800 ANTENNA, 136 TO 174 / 764 TO 870 MHz | COMANT INDUSTRIES | |
| A/R | 11 | 21-50-45 | VHF/UHF/700/800 ANTENNA, 136 TO 174 / 380 TO 870 MHz | COOPER ANTENNAS | |
| A/R | 12 | AV-925 | VHF/UHF/700/800 ANTENNA, 136 TO 174 / 380 TO 520 / 760 TO 870 MHz | RAMI ANTENNAS | |
| 1 | 13 | 7274-11-10 | CIRCUIT BREAKER, 10 AMPS | KLIXON | |
| 1 | 14 | RC-9000 | REMOTE CONTROL HEAD | TECHNISONIC INDUSTRIES LIMITED | |
| 1 | 15 | SRA-6000 | SWITCHED RECEIVE ATTENUATOR | TECHNISONIC INDUSTRIES LIMITED | |

NOTES:

- 1) ALL WIRE IAW MIL-W-22759 UNLESS OTHERWISE SPECIFIED.
- 2) ALL CABLE IAW MIL-C-27500 UNLESS OTHERWISE SPECIFIED.
- 3) COAXIAL CABLE IAW MIL-C-17 UNLESS OTHERWISE SPECIFIED. DO NOT USE COAX WITH PVC INSULATION.
- 4) FABRICATION & INSTALLATION OF WIRING HARNESS IAW AC 43.13-1B CHAPTER 11.
- 5) GROUNDING AND BONDING IAW AC 43.13-1B CHAPTER 11, SECTION 15.
- 6) ALL SINGLE WIRE TO BE #22 AWG MINIMUM AND ALL SHIELDED WIRE TO BE #24 AWG MINIMUM, UNLESS OTHERWISE SPECIFIED.
- 7) POWER AND GROUND WIRES TO BE #20 AWG.
- 8) ANTENNA COAX TO BE RG-142/U OR EQUIVALENT.
- 9) INSTALLATION OF ANTENNA IAW AC 43.13-1B CHAPTER 4, SECTION 4, CHAPTERS 6 & 7, AND AC 43.13-2A CHAPTER 3.
IF POSSIBLE, THE ANTENNA SHOULD BE LOCATED A MINIMUM OF 12 FT FROM AIRCRAFT NAVIGATION RECEIVER ANTENNAS AND A MINIMUM OF 4 FEET FROM AIRCRAFT COMMUNICATIONS AND ELT ANTENNAS. BE CAREFUL NOT TO CHOSE SEPARATIONS THAT CLOSELY APPROXIMATE 1/4 OR 1/2 OR WHOLE NUMBER MULTIPLES OF THE NAVIGATION OR COMMUNICATIONS WAVELENGTH.
- 10) AN EQUIVALENT CIRCUIT BREAKER OR FUSE MAY BE USED.
- 11) THE CHANNEL/BAND UP/DOWN PUSH BUTTONS ARE OPTIONAL. GROUND CHANNEL/BAND INPUT FOR BAND CONTROL, LEAVE UNCONNECTED FOR CHANNEL CONTROL.
- 12) THIS INPUT IS FOR BOTH 28 VDC AND 5 VAC PANEL LIGHTING. SELECT THE APPROPRIATE VOLTAGE IN THE CONFIGURATION MENU.
- 13) CONNECT TO THE APPROPRIATE AIRCRAFT DIMMING BUSS.
- 14) CONNECT TO THE AIRCRAFT AUDIO SYSTEM OR STAND-ALONE HEADSET JACKS.
- 15) INSTALLATION OF TRANSCEIVER IAW AC 43.13-1B CHAPTER 4, SECTION 4 AND AC 43.13-2A, CHAPTER 2. PR3 1/2 DZUS RAIL OR EQUIVALENT MAY BE USED.
- 16) TEST THE SYSTEM IN ACCORDANCE WITH THE POST-INSTALLATION TEST PROCEDURE IN THE INSTALLATION AND OPERATING INSTRUCTIONS MANUAL.
- 17) REFER TO THE AIRCRAFT STRUCTURAL REPAIR MANUAL AND THE MAINTENANCE MANUAL FOR INSTRUCTIONS AND INFORMATION PERTINENT TO THIS INSTALLATION.
- 18) THE USE OF RED DISPLAYS SHOULD BE MINIMIZED OR AVOIDED SO AS NOT TO DETRACT FROM THE ATTENTION GETTING CHARACTERISTICS NEEDED IN WARNING AND CAUTION ANNUNCIATORS. RED SHOULD BE USED TO ANNUNCIATE EMERGENCY CONDITIONS REQUIRING IMMEDIATE RESPONSE BY THE FLIGHT CREW. UNITS WITH RED DISPLAYS SHOULD NOT BE LOCATED IN CLOSE PROXIMITY TO WARNING AND CAUTION ANNUNCIATORS. THE INSTALLATION OF UNITS WITH RED DISPLAYS MUST BE EVALUATED ON A CASE BY CASE BASIS TO ENSURE THAT THE EFFECTIVENESS OF THE WARNING AND CAUTION ANNUNCIATORS IS NOT ADVERSELY AFFECTED.
- 19) NOT NORMALLY USED IN AIRCRAFT.
- 20) CONNECTION TO AN OPTIONAL RC-9000 SLAVE CONTROL HEAD.
- 21) CONNECTION TO AN OPTIONAL SRA-6000 SWITCHED RECEIVE ATTENUATOR.
- 22) OPTIONAL DONGLE USED WHEN A SINGLE AUDIO OUTPUT GROUND RETURN IS REQUIRED.

FIGURE 2.8 Wiring Connection Notes for the TDFM-9000 Transceiver

2.21 ANTENNA SELECTION AND INSTALLATION CONSIDERATIONS

Antenna installations will vary according to the number / type of bands installed in the TDFM-9000, types of antennas selected, and space available on the aircraft. The materials list above contains many but not all antennas available. If dual band RF modules are installed in the TDFM-9000, it is suggested to use a single connector, multiband antenna for each of the RF modules installed. When single band modules are installed, a single band antenna should be used. If the TDFM-9000 has more than one single band module installed that are on different frequency bands, a single multiband antenna with separate connectors or a multiband antenna with a coupler can be used if the frequencies in use are not multiples of each other. For example, transmitting near 150 MHz on VHF may interfere with frequencies near 450 MHz on the UHF band. Antennas should be spaced as far as possible from each other with the Comm antennas on the opposite side (top or bottom) from the FM antennas. See Technisonic's Transceiver Installation Guide and Antenna Selection Guide for more details.

2.22 POST INSTALLATION EMI TEST

PURPOSE

The purpose of this test is to identify any interference that the TDFM-9000 transceiver may cause with existing aircraft systems.

TEST CONDITIONS

The TDFM-9000 transceiver should be installed and function tested. The antenna VSWR should be checked. A forward/reverse power check with an in-line wattmeter should show no more than 10% reflected power. For the following tests, ensure that the output power is set to high.

METHODOLOGY

Most of the EMI tests can be accomplished on the ground. In some cases, flight testing is required or is easier. If the aircraft is approved for IFR operations, then it is mandatory that interference between the TDFM-9000 transceiver and the approach aids be checked in flight.

The GPS should be operational and navigating with at least the minimum compliment of satellites. The VHF comm should be set to the frequencies indicated with the squelch open. VOR/DME receivers should be set to the frequencies indicated and selected for display. If possible, set up a DME ramp test set on the frequencies indicated and adjust the output until the flags are out of view. The transponder and encoder should be monitored with ramp test equipment. Set the output of the transponder test set to 3db above the output necessary to achieve 90% reply. If possible, set the ADF to a nearby navigation station.

Modulate the TDFM-9000 transmitter on the indicated frequencies for at least 20 seconds.

Observe the GPS for any degradation in satellite status or availability or flags. Listen for any noise or detected audio signals on the VHF comm(s). Listen for any noise or detected audio signals on the VOR/LOC receiver audio; look for any moment of flags or needles on the VOR/LOC/GS navigation display(s). Observe the transponder for any loss of reply or spurious reply.

List the power plant, fuel, and other electric instruments in the chart provided and note any anomalies that occur while transmitting. Assess the results.

If the aircraft is equipped with an autopilot or a stability augmentation system, then test fly the aircraft and verify that operation of the TDFM-9000 transceiver does not have adverse effects on these systems. After checking for gross effects at a safe altitude, fly an approach with each of the different navigation systems coupled to the autopilot (ILS, GPS, etc.) and look for any anomalies.

TECHNISONIC INDUSTRIES LIMITED

RESULTS

If the installed system passes all of the applicable EMI tests, then no further action is required. If interference is observed, then the interference must be assessed against the appropriate standards of airworthiness for the system in question. For example, it is permissible for a VFR certified GPS to lose navigation capability while the TDFM-9000 unit is transmitting, providing that it recovers properly and promptly, but it is not permissible for an IFR Approach certified GPS to be affected in the same way. A complete discussion of all the standards of airworthiness to be applied in assessing EMI effects is beyond the scope of this document.

PROCEDURE

- A. Operate the TDFM-9000 transmitter on the following frequency for at least 20 seconds. Observe the GPS for any degradation in satellite status or availability or flags.

| FREQUENCIES | GPS #1 | | GPS #2 | |
|--------------|--------|------|--------|------|
| | PASS | FAIL | PASS | FAIL |
| TDFM-9000 | | | | |
| 143.2125 MHz | | | | |
| 143.2250 MHz | | | | |
| 157.5375 MHz | | | | |
| 157.5500 MHz | | | | |
| 512.0000 MHz | | | | |

NOTES:

TECHNISONIC INDUSTRIES LIMITED

- B.** Determine if the image frequency for the VHF Comm falls within the range of the TDFM-9000. If so, select a set of frequencies that will cause the TDFM-9000 to be set as close as possible to the image frequency. Any one of the many possible sets will suffice. Record those values in the spaces provided in the following chart. Modulate the TDFM-9000 transmitter on the following frequencies for at least 20 seconds. Listen for any noise or detected audio signals on the VHF comm.

Example - Bendix/King KY 196A:

The first IF frequency is 11.4 MHz. The L.O. is above the received frequency (high side injection); therefore, the image frequency is 22.8 MHz above the selected frequency. Set the KY 196A to 120.000 MHz and the TDFM-9000 to 142.8000 MHz.

| FREQUENCIES | | RESULTS | |
|---------------|-----------|---------|------|
| VHF #1 | TDFM-9000 | PASS | FAIL |
| 135.975 | 136.0000 | | |
| 121.150 | 157.5000 | | |
| 131.250 | 157.5000 | | |
| Image: | | | |
| | | | |
| | | | |

| FREQUENCIES | | RESULTS | |
|---------------|-----------|---------|------|
| VHF #2 | TDFM-9000 | PASS | FAIL |
| 135.975 | 136.0000 | | |
| 121.150 | 157.5000 | | |
| 131.250 | 157.5000 | | |
| Image: | | | |
| | | | |
| | | | |

NOTES:

TECHNISONIC INDUSTRIES LIMITED

- C.** Determine if the image frequency for the VOR/ILS Nav falls within the range of the TDFM-9000. If so, select two sets of frequencies that will cause the TDFM-9000 to be set as close as possible to the image frequency. Choose one set in the localizer frequency range and one in the VOR frequency range. Record those values in the spaces provided in the following chart. Modulate the TDFM-9000 transmitter on the following frequencies for at least 20 seconds. Listen for any noise or detected audio signals on the receiver audio; look for any moment of flags or needles on the navigation display.

| FREQUENCIES | | RESULTS | |
|---------------|-----------|---------|------|
| VOR/ILS #1 | TDFM-9000 | PASS | FAIL |
| 108.000 | 162.0000 | | |
| 108.100 | 162.1500 | | |
| Image: | | | |
| | | | |
| | | | |

| FREQUENCIES | | RESULTS | |
|---------------|-----------|---------|------|
| VOR/ILS #2 | TDFM-9000 | PASS | FAIL |
| 108.000 | 162.0000 | | |
| 108.100 | 162.1500 | | |
| Image: | | | |
| | | | |
| | | | |

NOTES:

TECHNISONIC INDUSTRIES LIMITED

- D.** The following procedure checks for second harmonic interference to the glide slope receiver from the TDFM-9000. All transceivers produce harmonics (multiples of the wanted frequency) and while the TDFM-9000 far exceeds FCC requirements, interference can still be experienced depending upon antenna position and separation. Furthermore, other equipment in the aircraft and the structure of the aircraft can generate harmonics where dissimilar metals make contact or where grounds are isolated, etc. This is also true of aircraft hangars; therefore, testing should be done outside away from any structures where possible.

With a portable glide slope generator, provide enough signal to firmly activate the indicator needle and hide all flags. Increase the signal level by 3 dB. Modulate the TDFM-9000 transmitter on the following frequencies for at least 20 seconds. Observe the Glide Slope displays. Look for any movement of flags or needles on the navigation display. If an interference condition is detected, then the installation will have to be flight tested according to the following procedure. Using the table below, determine the glide slope frequency based on the localizer frequency of the ILS to be used. Divide the glide slope frequency by 2 and program into the TDFM-9000. Fly the aircraft to intercept the localizer and glide slope (both needles centered) at 26 nm from the runway. Transmit on the TDFM-9000 for 10 seconds and watch for any deflections or flags. Repeat the test every 2 nm until the indicators are not affected. If the distance is greater than 18 nm, then a pass shall be recorded. Otherwise the TDFM-9000 shall be placarded "Do not transmit while on ILS approach."

| Localizer | Glide slope | Localizer | Glide slope |
|-----------|-------------|-----------|-------------|
| 108.10 | 334.70 | 110.10 | 334.40 |
| 108.15 | 334.55 | 110.15 | 334.25 |
| 108.30 | 334.10 | 110.30 | 335.00 |
| 108.35 | 333.95 | 110.35 | 334.85 |
| 108.50 | 329.90 | 110.50 | 329.60 |
| 108.55 | 329.75 | 110.55 | 329.45 |
| 108.70 | 330.50 | 110.70 | 330.20 |
| 108.75 | 330.35 | 110.75 | 330.05 |
| 108.90 | 329.30 | 110.90 | 330.80 |
| 108.95 | 329.15 | 110.95 | 330.65 |
| 109.10 | 331.40 | 111.10 | 331.70 |
| 109.15 | 331.25 | 111.15 | 331.55 |
| 109.30 | 332.00 | 111.30 | 332.30 |
| 109.35 | 331.85 | 111.35 | 332.15 |
| 109.50 | 332.60 | 111.50 | 332.90 |
| 109.55 | 332.35 | 111.55 | 332.75 |
| 109.70 | 333.20 | 111.70 | 333.50 |
| 109.75 | 333.05 | 111.75 | 333.35 |
| 109.90 | 333.80 | 111.90 | 331.10 |
| 109.95 | 333.65 | 111.95 | 330.95 |

TECHNISONIC INDUSTRIES LIMITED

| FREQUENCIES | | RESULTS | |
|---------------|-----------|---------|------|
| G/S #1 | TDFM-9000 | PASS | FAIL |
| 334.7 (108.1) | 167.35 | | |
| | | | |

| FREQUENCIES | | RESULTS | |
|---------------|-----------|---------|------|
| G/S #2 | TDFM-9000 | PASS | FAIL |
| 334.7 (108.1) | 167.35 | | |
| | | | |

NOTES:

- E.** Operate the TDFM-9000 transmitter on the following frequency for at least 20 seconds. Observe the Transponder for any spurious replies or loss of reply to test set.

| FREQUENCIES | TRANSPONDER #1 | | TRANSPONDER #2 | |
|-------------|----------------|------|----------------|------|
| | PASS | FAIL | PASS | FAIL |
| 512 MHz | | | | |

NOTES:

TECHNISONIC INDUSTRIES LIMITED

- F.** Modulate the TDFM-9000 transmitter on the following frequencies for at least 20 seconds. Observe the DME displays. Look for loss of distance information on the display.

| FREQUENCIES | | RESULTS | |
|--------------------|------------------|----------------|-------------|
| DME 1 | TDFM-9000 | PASS | FAIL |
| 978 (108.0) | 489 | | |
| 1020 (112.1) | 510 | | |
| | | | |

| FREQUENCIES | | RESULTS | |
|--------------------|------------------|----------------|-------------|
| DME 2 | TDFM-9000 | PASS | FAIL |
| 978 (108.0) | 489 | | |
| 1020 (112.1) | 510 | | |
| | | | |

NOTES:

TECHNISONIC INDUSTRIES LIMITED

- G.** **NOTE:** For the following tests, select a frequency at the top, middle, and bottom of each band of the TDFM-9000 transceiver.

136 to 174 MHz
Band

403 to 470 MHz
Band

450 to 512 MHz
Band

806 to 870 MHz
Band

Frequency #1

Frequency #2

Frequency #3

- H.** At a safe altitude, engage the autopilot or stability augmentation system. Modulate the TDFM-9000 transmitter on the above frequencies for at least 20 seconds. Observe any effect on the autopilot or stability augmentation system.

Observations:

- I.** Perform a coupled ILS approach to the aircraft's certified limits. Modulate the TDFM-9000 transmitter on the above frequencies for at least 20 seconds. Observe any effect on the autopilot. Repeat for second flight director/autopilot if equipped.

Observations:

TECHNISONIC INDUSTRIES LIMITED

J. List the power plant, fuel and other electric instruments in the chart provided and note any anomalies that occur while transmitting. Assess the results.

| STEP | SYSTEM | PASS | FAIL | NOTES |
|-------------|---|-------------|-------------|--------------|
| 1 | Com 1 & 2 (UHF Lo, UHF Hi, and 800 MHz) | | | |
| 2 | Transponder & Encoder (VHF, UHF Lo, and 800 MHz) | | | |
| 3 | ADF 1 & 2 | | | |
| 4 | VG | | | |
| 5 | Glideslope 1 & 2 (UHF Lo, UHF Hi, and 800 MHz) | | | |
| 6 | VOR/LOC 1 & 2 (UHF Lo, UHF Hi, and 800 MHz) | | | |
| 7 | Compass | | | |
| 8 | Directional Gyro | | | |
| 9 | Fuel Pressure | | | |
| 10 | Oil Temp | | | |
| 11 | Amps | | | |
| 12 | Bus Voltage | | | |

TECHNISONIC INDUSTRIES LIMITED

| | | | | |
|----|---|--|--|--|
| 13 | Fuel % | | | |
| 14 | Ng | | | |
| 15 | TOT | | | |
| 16 | Torque % | | | |
| 17 | Annunciators | | | |
| 18 | Digital Clock | | | |
| 19 | Oil Pressure | | | |
| 20 | DME 1 & 2 (VHF, UHF Lo, and 800 MHz) | | | |
| 21 | GPS 1 & 2 (UHF Lo and 800 MHz) | | | |
| | | | | |
| | | | | |
| | | | | |
| | | | | |
| | | | | |
| | | | | |
| | | | | |
| | | | | |

TECHNISONIC INDUSTRIES LIMITED

| STEP | SYSTEM | PASS | FAIL | NOTES |
|------|--------|------|------|-------|
| | | | | |
| | | | | |
| | | | | |
| | | | | |
| | | | | |
| | | | | |
| | | | | |

NOTES:

APPENDIX A

SUPPORT NOTES

- For the latest Service Bulletin(s) refer to the Publication Index list under the section for this model (*login required*).
- For the latest Technical Information Bulletins refer to the Publication Index list under the section for this model (*login required*).
- For the latest Software Release(s) refer to the Publication Index list under the section for this model's software/firmware history index (*login required*).

NOTES

TECHNISONIC INDUSTRIES LIMITED

Technisonic Industries Limited

240 Traders Blvd., Mississauga, ON Canada L4Z 1W7

Tel: (905) 890-2113 Fax: (905) 890-5338

**IMPORTANT
WARRANTY**

All communication equipment manufactured by Technisonic Industries Limited is warranted to be free of defects in Material or Workmanship under normal use for a period of one year from Date of Purchase by the end user.

Warranty will only apply to equipment installed by a factory approved and/or authorized facility in accordance with Technisonic published installation instructions. Equipment falling under the following is not covered by warranty:

- Equipment that has been repaired or altered in any way as to affect performance
- Equipment that has been subject to improper installation
- Equipment that has been used for purposes other than intended
- Equipment that has been involved in any accident, fire, flood, immersion, or subject to any other abuse.

Expressly excluded from this warranty are changes or charges relating to the removal and re-installation of equipment from the aircraft. Technisonic will repair or replace (at Technisonic's discretion) any defective transceiver (or part thereof) found to be faulty during the Warranty Period.

Faulty equipment must be returned to Technisonic (or its authorized Warranty Depot) with transportation charges prepaid. Repaired (or replacement) equipment will be returned to the customer with collect freight charges. If the failure of a transceiver occurs within the first 30 days of service, Technisonic will return the repaired or replacement equipment prepaid.

Technisonic reserves the right to make changes in design, or additions to, or improvements in its products without obligation to install such additions and improvements in equipment previously manufactured. This Warranty is in lieu of any and all other warranties express or implied, including any warranty of merchantability or fitness, and of all other obligations or liabilities on the part of Technisonic.

This Warranty shall not be transferable or assignable to any other persons, firms, or corporations.

**For warranty registration, please complete the on-line
Warranty Registration Form found at www.til.ca.**